

robot coupe®

CL 30 A

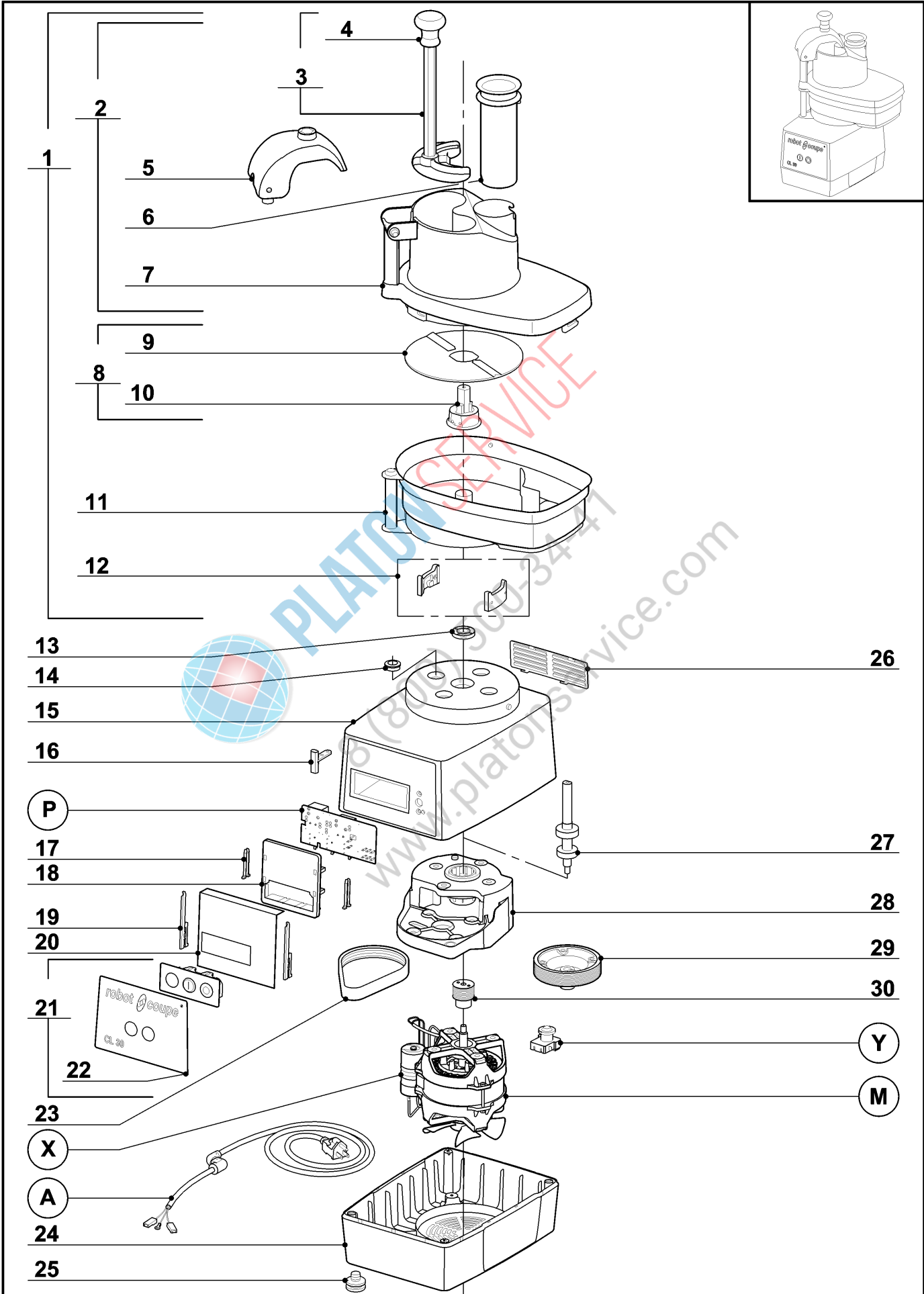
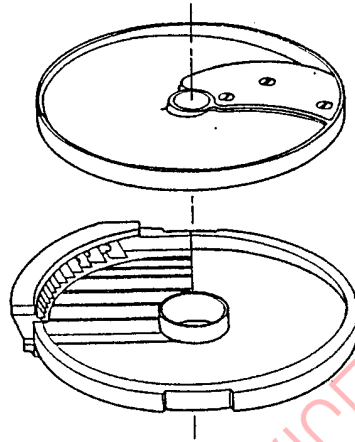

Index	Pièce / Part	Désignation	Description			
1	27 252	ENS COUPE LEGUMES	VEGETABLE SLICER ASSEMBLY			
2	117 079	TETE COUPE LEGUMES COMPLETE	VEGETABLE SLICER HEAD			
3	29 324	ENS POUSSOIR	PUSHER ASSEMBLY			
4	102 021	POIGNEE	HANDLE KNOB			
5	102 020	GUIDE POUSSOIR	PUSHER GUIDE			
6	102 022	POUSSOIR CAROTTES	ROUND PUSHER			
7	102 016	COUVERCLE COUPE LEGUMES	VEGETABLE SLICER LID			
8	102 019	DISQUE EVACUATEUR	SLING PLATE			
9	117 092	DISQUE EVACUATEUR REVERSIBLE	REVERSIBLE SLING PLATE			
10	117 091	MOYEU DISQUE EVACUATEUR	SLING PLATE HUB			
11	104 076	CUVE COUPE LEGUMES	VEGETABLE SLICER BOWL			
12	29 081	ENS PLAQUETTE	LOCKING PLATE ASSEMBLY			
13	501 010	BAGUE ETANCHEITE	MOTOR SEAL			
14	104 070	CAPSULE CACHE VIS	BOLT COVER			
15	39 117	ENS SUPPORT MOTEUR	MOTOR SUPPORT ASSEMBLY			
16	29 356	ILS COMPLET COUPE LEGUMES	VEGETABLE REED SWITCH			
17	102 913	CLAVETTE PLASTRON	PANEL KEY			
18	102 911	SUPPORT PLATINE	PCB SUPPORT			
19	117 703	CLAVETTE FIXE PLATINE	PCB KEY			
20	104 131	PROTEGE PLATINE	PCB PROTECT			
21	39 115	ENS TABLEAU COMMANDE	SWITCH ASSEMBLY			
22	407 705	PLAQUE FRONTALE	FRONT PLATE			
23	503 940	COURROIE	BELT			
24	39 112	ENS SOCLE	BASE ASSEMBLY			
25	101 082	PIED	FOOT			
26	104 122	GRILLE VENTILATION INOX	VENT COVER			
27	29 604	ENS AXE TRANSMISSION	TRANSMISSION SHAFT ASSEMBLY			
28	104 125	SUPPORT TRANSMISSION	TRANSMISSION SUPPORT			
29	102 923	POULIE RECEPTRICE	LARGE PULLEY			
30	102 924	POULIE MOTRICE	SMALL PULLEY			
<b>A</b>		CABLE D'ALIMENTATION	POWER CORD			
<b>M</b>		MOTEUR	MOTOR			
<b>P</b>		PLATINE	CIRCUIT BOARD			
<b>X</b>		CONDENSATEUR	CAPACITOR			
<b>Y</b>		RELAIS MOTEUR	MOTOR RELAY			
Machine	Voltage	A	M	P	X	Y
24 383	230/50/1	504 274	3 122	103 691	600 018	500 289
24 384 UK	240/50/1	504 275	3 122	103 691	600 018	500 289
24 385 Aust	240/50/1	504 278	3 122	103 691	600 018	500 289
24 386	120/60/1	504 277	3 125	103 690	603 669	500 296
24 387	220/60/1	504 274	3 123	103 691	603 669	500 289
24 389 DK	230/50/1	504 276	3 122	103 691	600 018	500 289
2 685 Pack 6D SWE	230/50/1	504 274	3 122	103 691	600 018	500 289

**EQUIPEMENT FRITES / FRENCH FRIES EQUIPMENT**

27 116\* : 8 x 8

- EMINCEUR 8 : 29 343  
- LAME : 102 036  
- GRILLE 8 : 102 066

27 117\* : 10 x 10

- EMINCEUR 10 : 29 344  
- LAME : 102 036  
- GRILLE 10 : 102 067

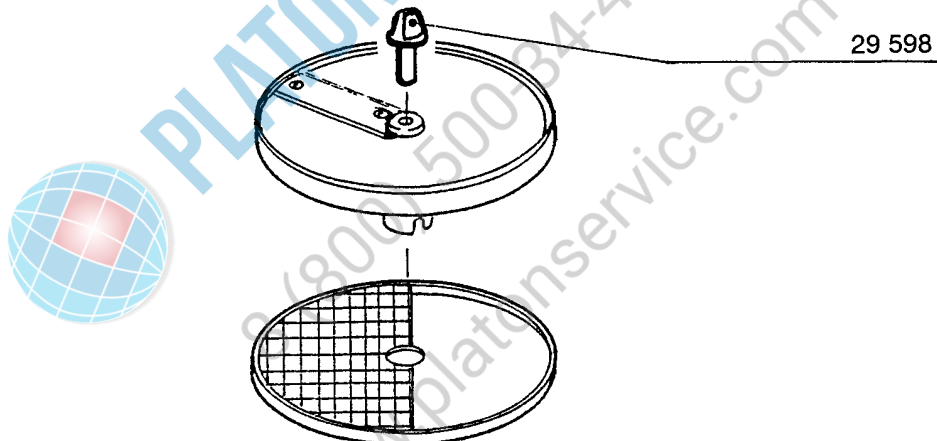
**EQUIPEMENT MACEDOINE / DICING EQUIPMENT**

27 113\* : 8 x 8

- EMINCEUR 8 : 29 333  
- LAME : 102 120  
- GRILLE 8 : 102 064

27 114\* : 10 x 10

- EMINCEUR 10 : 29 334  
- LAME : 102 120  
- GRILLE 10 : 102 065

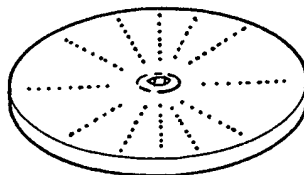
**RAPEUR / GRATER**

27 148\* : RAPEUR 1,5mm / GRATER 1,5mm  
27 149\* : RAPEUR 2 mm / GRATER 2 mm  
27 159\* : RAPEUR 3 mm / GRATER 3 mm